

7.3 VOLUMES

Just like in the last section where we found the area of one arbitrary rectangular strip and used an integral to add up the areas of an infinite number of infinitely thin rectangles, we are going to apply the same concept to finding volume. The key ... Find the volume of ONE arbitrary "slice", and use an integral to add up the volumes of an infinite number of infinitely thin "slices".

We will first apply this concept to the volume of a solid with a known cross section, then we will find the volumes of solids formed by revolving a region about a horizontal or vertical line. We will discuss three different methods of finding volumes of solids of revolution, but first ...

Day 1: Volumes of Solids with Known Cross Sections

First Question ... What is a cross section? Imagine a loaf of bread. Now imagine the shape of a slice through the loaf of bread. This shape would be a cross section. Technically a *cross section* of a three dimensional figure is the intersection of a plane and that figure. It would be like cutting an object and then looking at the face of where you just cut.

The cross sections we will be dealing are almost entirely perpendicular to the x - axis.

Here's the basic idea ... You will be given a region defined by a number of functions. We will graph that region on an x and y axis. Then we will lay that region flat and build upon that region a solid which has the same cross section no matter where you slice it.

To see some animated views of this go to <http://mathdemos.gcsu.edu/mathdemos/sectionmethod/sectiongallery.html>

Second question ... How do we find the volume of this solid that has been created to have a similarly shaped cross section, even though each cross section may have a different size? We get to use calculus, of course! But first, we need to know how to find the Volume of a prism. Even though every shape may be different, we can find the volume of a prism by finding the area of the base times the "height". The "height" of our prisms will be the thickness of the slices. Once you know the volume of one slice, you just use an integral to add the volumes of all the slices to get the volume of the solid.

Example 1: Find the volume of the following square "slice". Since most of the "slices" we will be dealing with will have a thickness of dx , we will use that same thickness here.

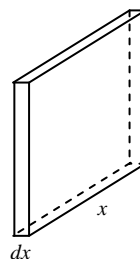

Example 2: Find the volume of the following semicircular "slice".

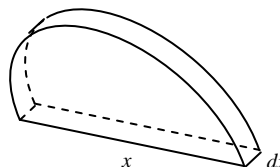

You will also need to be able to find the volume of equilateral triangle cross sections, isosceles right triangle cross sections, and others. Remember, what you really need is a formula for the area of the base, which is just the cross sectional shape.

Example 3: The base of a solid is the region in the first quadrant enclosed by the parabola $y = 4x^2$, the line $x = 1$, and the x -axis. Each plane section of the solid perpendicular to the x -axis is a square. The volume of the solid is

- A) $\frac{4\pi}{3}$
- B) $\frac{16\pi}{5}$
- C) $\frac{4}{3}$
- D) $\frac{16}{5}$
- E) $\frac{64}{5}$

Example 4: The base of a solid is a region in the first quadrant bounded by the x -axis, the y -axis, and the line $x + 2y = 8$. If the cross sections of the solid perpendicular to the x -axis are semicircles, what is the volume of the solid?

- A) 12.566
- B) 14.661
- C) 16.755
- D) 67.021
- E) 134.041

Example 5: The base of a solid is the region in the first quadrant enclosed by the graph of $y = 2 - x^2$ and the coordinate axes. If every cross section of the solid perpendicular to the y -axis is a square, the volume of the solid is given by

- A) $\pi \int_0^2 (2 - y)^2 dy$
- B) $\int_0^2 (2 - y) dy$
- C) $\pi \int_0^{\sqrt{2}} (2 - x^2)^2 dx$
- D) $\int_0^{\sqrt{2}} (2 - x^2)^2 dx$
- E) $\int_0^{\sqrt{2}} (2 - x^2) dx$

Day 2: Volumes of Solids of Revolution: The Disc Method

In finding the area of a region, we drew an arbitrary representative rectangle. Keeping with the same idea, if we revolve a rectangle around a line, it forms a cylinder, as shown below. The key to using the disc method will be twofold: 1) The rectangular strip must be connected to the axis of revolution (no matter where you draw it), and 2) the rectangular strip must be perpendicular to the axis of revolution.



Example 6: What is the volume of the cylinder shown if the height of the rectangle is considered R and the width of the rectangle is dx ?

Just like we did in finding the area, as we increase the number of rectangles to infinity, the width of each rectangle becomes infinitely small and we denote this dx (if it is a vertical strip) or dy (if it is a horizontal strip). We then use an integral to sum the volume of every one of these infinitely thin cylinders. This concept leads to the following:

The Disc Method

To find the volume of a solid of revolution with the *disc method*, use one of the following;

HORIZONTAL AXIS OF REVOLUTION

$$V = \pi \int_a^b [R(x)]^2 dx$$

VERTICAL AXIS OF REVOLUTION

$$V = \pi \int_a^b [R(y)]^2 dy$$

where $R(x)$ and $R(y)$ are the "heights" of your representative rectangular strips.

Example 7: Draw an appropriate rectangular strip and find the volume of the solid formed by revolving the region about the x -axis.

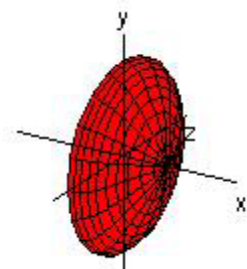
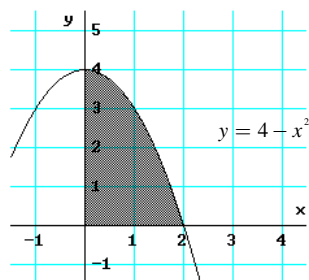

Example 8: Find the volume of the solid formed by revolving the region about the y – axis. (Draw a representative rectangular strip)

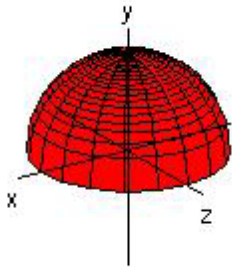
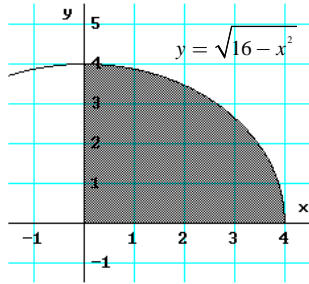

Example 9: Find the volume of the solid generated by revolving the region bounded by the graphs of the equations $xy = 6$, $y = 2$, $y = 6$, and $x = 6$ about the indicated lines. Sketch the region formed, and draw a representative rectangular strip for each solid.

a) the line $x = 6$.

b) the line $y = 6$.

Day 3: Volumes of Solids of Revolution: The Washer Method

For the disc method, the area we revolved had to be connected to the area of rotation and the representative rectangle had to be perpendicular to the axis of revolution. For the washer method, the representative rectangle will still be perpendicular to the axis of revolution, but no longer attached to the axis of revolution.

Example 10: Sketch the figure formed by rotating the rectangle around the given line. Do you see why it's called the washer method?

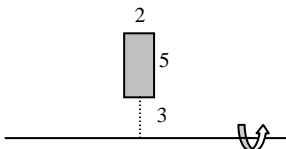

Example 11: What is the volume of the figure formed above?

We will call the outer radius R , and we will call the inner radius r . The height of the cylinder formed is just the width of the strip. Just like before, if we have an infinitely thin strip, this distance will be denoted dx (if it is a vertical strip) and dy (if it is a horizontal strip).

The volume of the solid formed by revolving a region around the axis using the **washer method** is given by

$$\pi \int_a^b [R^2 - r^2] dx$$

Example 12: Set up an integral, but do not solve to find the volume of the solid generated by revolving the region bounded by the graphs of the equations about the indicated lines.

$$y = 2x^2; \quad y = 0; \quad x = 2$$

a) the y – axis

b) the x – axis

c) the line $y = 8$

d) the line $x = 2$

Day 4: Volumes of Solids of Revolution: The Shell Method

We have now used two different methods to find the volume of a solid formed by revolving a region about a line. As with the disc and washer methods we will begin our discussion of the shell method by considering a rectangle having width w and length h . The major difference between the shell method and the previous methods is that the rectangle will be *parallel* to the axis of revolution.

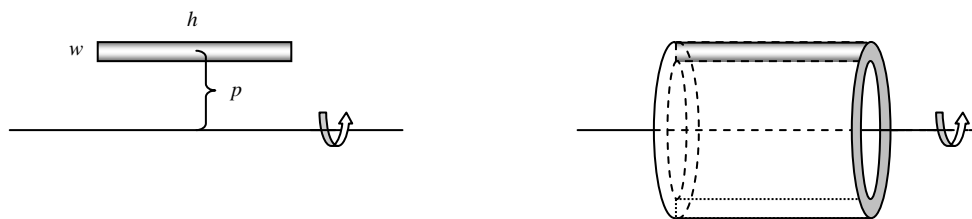

♪: Let p be the distance between the axis of revolution and the *CENTER* of the rectangular strip.

Finding the volume is done similarly to the washer method.

Example 14: If p is defined as above to be the distance between the axis of revolution and the *center* of the rectangular strip, then what is the radius of the “outer” cylinder?

Example 15: What is the volume of the “outer” cylinder?

Example 16: What is the radius of the “inner” cylinder? The volume of the “inner” cylinder?

Example 17: What is the volume of the shell?

If we were to rotate the figure below around the line given, we could estimate the volume of the solid formed by finding the volume of the solid formed by rotating each rectangular strip and adding these volumes together. If we were to consider infinitely many strips, then each strip would be so incredibly thin that the average radius, p , would be the distance between the axis of revolution and the strip. The height of the shell formed by each strip is just the length of the strip, h , and the thickness of each strip is given by dy (if the strip is horizontal) or dx (if the strip is vertical).

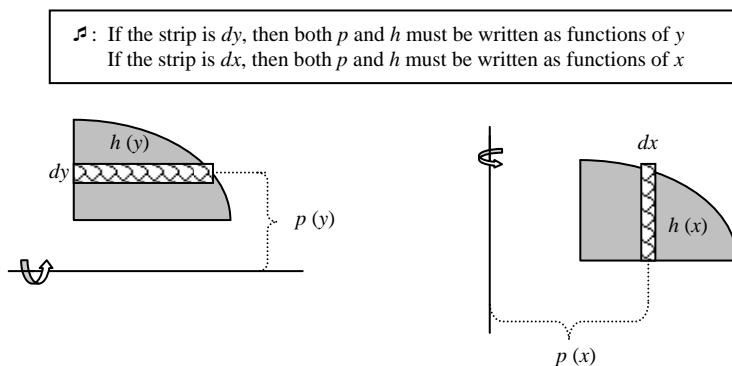

The Shell Method	
Horizontal Axis of Revolution	Vertical Axis of Revolution
$V = 2\pi \int_a^b p(y)h(y) dy$	$V = 2\pi \int_a^b p(x)h(x) dx$

Example: Let R be the region bounded by the graphs of $y = \frac{1}{x}$, $y = 0$, $x = 1$, and $x = 4$. In the last example, we were able to use both the disc and shell methods to arrive at the same answer. Explain why the volume formed by revolving R around the y – axis is best found using the shell method instead of the disc and washer methods. Set up and evaluate the integral that gives the volume formed by revolving R around the y – axis.

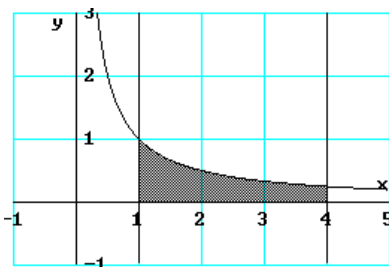

Example: Find the volume of the solid formed by revolving the region bounded by the graphs of $y = x^3 + x + 1$, $y = 1$, and $x = 1$ about the line $x = 2$. Explain why it is necessary to use the shell method in this problem.

